



INTERNATIONAL JOURNAL OF ENGINEERING SCIENCES & RESEARCH TECHNOLOGY

MATLAB SIMULATIV STUDY OF SEPIC CONVERTER

Ashfaq Shah*, S.P. Phulambrikar

* Electrical Engg.Deptt. S.A.T.I. Vidisha, R.G.P.V. University, Bhopal(India).
Electrical Engg.Deptt. S.A.T.I. Vidisha, R.G.P.V. University, Bhopal(India).

ABSTRACT

A high-power-factor rectifier suitable for universal line base on a modified version of the single-ended primary inductance converter (SEPIC) is presented in this. paper. The voltage multiplier.technique is applied to the classical SEPIC.circuit, obtaining new.operation characteristics as low-switch-voltage operation and high static gain at low.line voltage. The new configuration.also allows the reduction of the losses associated to the diode reverse.recovery current and soft commutation is obtained with a simple regenerative.snubber circuit. single-ended.primary inductance.converter (SEPIC) step up the input voltage 220 Vdc to 1200 Vdc with the switching frequency of 24 kHz. For close loop operation of single-ended primary inductance converter (SEPIC) with PI controller that uses to control the behaviors of the system in linear .This arrangement has close loop system. The computer program used for simulation of SEPIC is MATLAB SIMULINK & . This project consists of design, simulating the model and stability and other analysis of proposed model.

KEYWORDS: single-ended primary inductanceconverter (SEPIC), high power factor (HPF), current controller (VCi)

INTRODUCTION

RESEARCH BACKGROUND

Circuits run best with a steady and specific input Controlling the input to specific sub circuits is crucial for full filling design requirements. AC to AC conversion can be easily done with the transformer however dc dc conversion is not as simple. Diodes and voltage bridges are useful for the reducing voltage by a set amount but can be inefficient. Voltage regulators are used to provide reference voltage. additionally battery voltage decreases as batteries discharge which can cause many problems if there is no voltage control. the most efficient method of regulating voltage through a circuit is with the dc dc converter. There are five main types of dc dc converters. Buck converters can only reduce voltage and boost converters only increase voltage and buck boost CUK and SEPIC converters can increase or decrease the voltage.

NEED FOR A BETTER TECHNIQUE

- Can deliver high boost ratio with minimum voltage and current stress being imposed on the Switches so that moderately rated (for example 30 V to 100 V range) MOSFETs
- Can operate at moderate duty cycles (for example less than 85% to 90%) for easier CCM and PWM control.
- Are true switchers without the drawbacks (including low output current) overcharge pumps
- Avoid the voltage spikes and ringing associated with transformer leakage inductance.

Some applications of converters only need to buck or boost the voltage and can simply use the corresponding converters. However sometimes the desired output voltage will be in the range of input voltage when this is the case it is usually best to use a converter that can decrease or increase the voltage Buck boost converters can be cheaper because they only require a single inductor and capacitor. However these converters suffer from a high amountinput current ripple this ripple can create harmonic in many applications these harmonics using a large capacitor or an LC filter. This often makes the buck and boost expensive or inefficient. Another issue that can complicate the usage of buck boost converters is that they invert the voltage. CUK converters solve both of these problems by using extra capacitor and inductor. However both CUK and buck boost converter operation cause large amounts of electrical stress on the components this

can result in device failure or overheating. THE BOOST converter is the usual structure utilized in high power factor (HPF) rectifiers in order to improve power factor (PF) and reduce the total current harmonic distortion (THD). However for universal input voltage application the efficiency can be reduced mainly in the lowest input voltage and the worst operation condition must be considered in the power converter design procedure. The improvement of the efficiency at lower line voltage is important because the thermal design and heat sinks size are defined considering the worst operation point. Many works were developed in order to improve the operation characteristics of the power converter utilized in HPF universal input rectifiers. A review of the main single-phase topologies and techniques used in an HPF rectifier is presented in discussion about the use of single stage and two stages structures is presented in two switches topology for universal input HPF rectifier is presented in. Some single stage isolated HPF rectifiers are presented in. The use of high static gain and low switch voltage topologies can improve the efficiency operating with low input voltage, as presented in. The voltage multiplier technique was presented in for a boost converter in order to increase the static gain with reduced switch voltage. However the boost voltage doublers cannot be used for a universal input voltage HPF rectifier because the output voltage must be higher than the double of the maximum input voltage modification in the multiphase boost voltage doubler was proposed in for a universal input HPF rectifier in order to obtain high static gain at the lower input voltage with the same dc output voltage level of a classical boost converter ($V_o = 400\text{ V}$).

The integration of a voltage multiplier cell with a classical single ended primary inductance converter (SEPIC) is proposed in this paper in order to obtain a high step-up static gain operating with low input voltage and a low step-up static gain for the high input voltage operation. The operation characteristics obtained with this modification makes the proposed structure an interesting alternative for the universal input HPF rectifier or wide input voltage range applications operating with high efficiency. The proposed converter operates with a switch voltage lower than the output voltage and with an input current ripple lower than the classical boost converter. The power circuit of the proposed converter can be integrated with a simple regenerative snubber obtaining soft switching commutation and increasing the efficiency.

Main goal in power electronics is to transform electrical energy from one form to another to make electrical energy to reach the load with highest efficiency is the target to be achieved power electronics also target to reduce the size of the device to convert these energy which aims to reduce cost, smaller in size and high availability in this project the power electronics device that use to dc to dc converter.

The dc-dc converter for this project is single ended primary inductance converter. It is used to convert unregulated dc input to a controlled dc output with desired voltage level. The single ended primary inductance converter step up the input voltage 220 Vdc to 1200 Vdc with the switching frequency 24 kHz. For close loop operation of SEPIC with PI controller that uses to control the behaviors of the system in linear. This arrangement is a close loop system. The software used to do simulation is MATLAB SIMULINK. This project consists of designing simulation and stability and other analysis.

INTRODUCTION

A dc converter can be considered as dc equivalent to an ac transformer with a continuously variable turn ratio like a transformer it is used to step down or step up a dc voltage source. There are various dc dc converters such as buck (step down) boost (step up) and buck-boost and cuk converter the basic step down and step up converters can be transformed into a number of new topologies by bringing in the tapped inductor. Switching regulators are preferred over linear regulators for their high efficiency and providing step up step down or inverter output unlike linear regulator which does only step down operations in reality the conversion efficiency of linear regulators is limited to only 30% and they find application in analog circuits to ensure nearly constant supply voltage providing high power supply rejection ratio. In switching controller circuits semiconductor switches regulate the dynamic transfer of power from input to output with very short transition times due to this switching action there is ripple added to output voltage the output should be a dc voltage with a minimum superimposition of ac ripple. Pulse width modulation is the most widely used method for controlling the output voltage. It holds a constant switching frequency and varies the duty cycle. Duty cycle is well defined as the ratio of switch on time to reciprocal of the switching frequency. Meanwhile the switching frequency is fixed this modulation arrangement has a relatively narrow noise spectrum allowing a simple low pass filter to sharply reduce peak to peak ripple at output voltage his requirement is achieved by arranging an inductor and capacitor in the converter in such a manner as to form a low pass filter network this needs the frequency of low pass filter to be much less than switching frequency. The

following section discusses various converter topologies and their operation. Perfect circuits are considered for ease of understanding and explanation. The main difference between each is the arrangement of the switches and output filter inductor and capacitor.

GENERAL

The purpose of this project is to design and optimize a SEPIC dc to dc converter. The SEPIC converter allows a range of dc voltage to be adjusted to maintain the constant voltage output. This project talks about the importance of dc to dc converters and why SEPIC converters are used instead of other dc to dc converters. This project also details about how to control the output of the converter with either a potentiometer or feedback to show how it can be implemented. A circuit from these projections learns dc to dc converter optimization and control.

PROPOSED SEPIC Converter TOPOLOGY

The proposed SEPIC Converter is illustrated in Fig 3.1

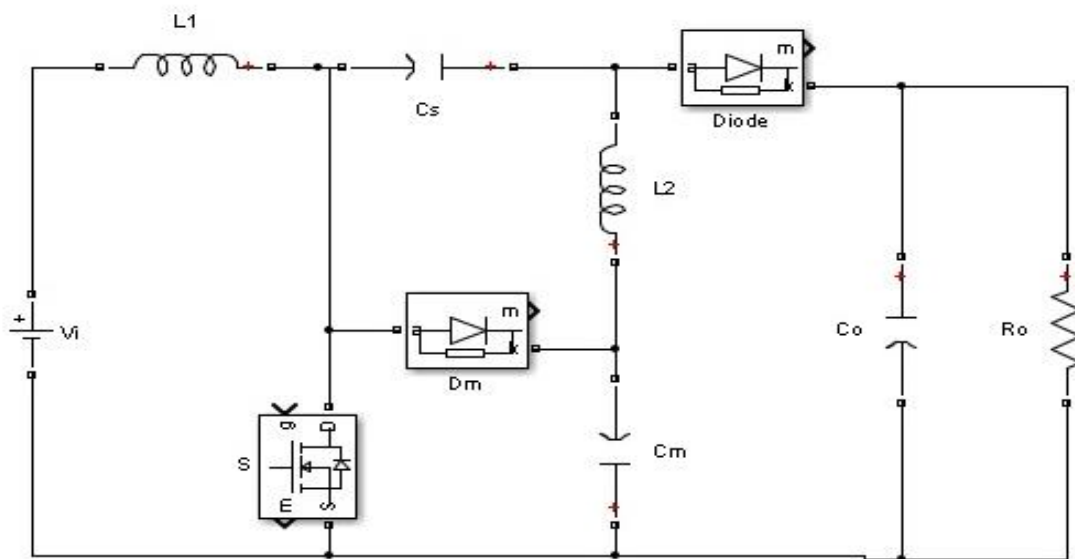

Fig 2.1 Modified SEPIC converter

The power circuit of classical SEPIC converter is presented in the stepup and stepdown static gains of the SEPIC converter is an interesting operation characteristic for a wide input voltage range application however the switch voltage is equal to the sum of the input and output voltages this topology is not used for universal input HPF rectifier.

The voltage multiplier technique was presented in order to increase the static gain of single-phase and multiphase boost dc to dc converters. An adaptation of the voltage multiplier technique with the SEPIC the inclusion of the diode D_m and the capacitor C_m . Many operational characteristic C_s of the classical SEPIC converter are changed with proposed modification.

CONTROL SCHEME

Control algorithm of the proposed converter is based on classical structure of the average current mode control with the digital implementation and the power system operating in CCM. The design procedure of the control system for the boost converter is well established and used in this implementation. The implementation of the control system for the proposed converter is accomplished by using exactly the same control designed for the classical boost converter this approximation is possible because the additional poles inserted by the inductor L_2 and capacitors C_s and C_m occur in a frequency higher than the poles inserted by inductor L_1 and the output

Filter capacitor C_o the capacitors C_s and C_m are very small comparing with the output filter capacitor. The inductor L_2 is also a made of the input inductor L_1 . As the crossing frequencies of voltage and current control loops are lower than frequency of the lower frequency poles the additional higher frequency poles does not present a significant influence in the phase margin and the gain margin thus maintaining approximately the same dynamic response for both power stage structures in order to show this characteristic the same control algorithm designed for the classical boost converter is used with the proposed converter and the experimental results obtained confirm this consideration. The control algorithm is developed using the MC56F8013 digital signal controller operating with a sampling rate equal to 24 kHz. The sample of the output voltage is compared with a reference of the output voltage. The error signal obtained is applied to a digital proportional integral controller. The result obtained from the voltage controller is multiplied by a sample of the rectified input voltage and the resultant signal is the reference waveform for the current control loop (i_{ref}). The sampling of the rectified input current is compared with the current reference. The result (E_i) is applied to a digital PI controller. The output of the current controller (V_{C_i}) is applied to the pulse width modulator generating the command signal of the power switch.

OPERATING PRINCIPLE OF SEPIC CONVERTER

The capacitor C_M is charged with the output voltage of the classical boost converter. Therefore the voltage applied to the inductor L_2 during the conduction of the power switch is higher than that in the classical SEPIC thereby increasing the static gain. The polarity of the voltage stored in the capacitor C_S is inverted in the proposed converter the continuous conduction mode operation of the modified SEPIC converter presents the following two operation stages.

- [1] **First stage** ($[t_0 \text{ to } t_1]$):-At the instant t_0 the switch S is turned-off and the energy stored in the input inductor L_1 is transferred to the output through the capacitor C_S and output diode D_o and also to the capacitor C_m through the diode D_m Therefore the switch voltage is equal to the capacitor C_m voltage. The energy stored in the inductor L_2 is transferred to the output through the diode D_o .

First Operation Stage

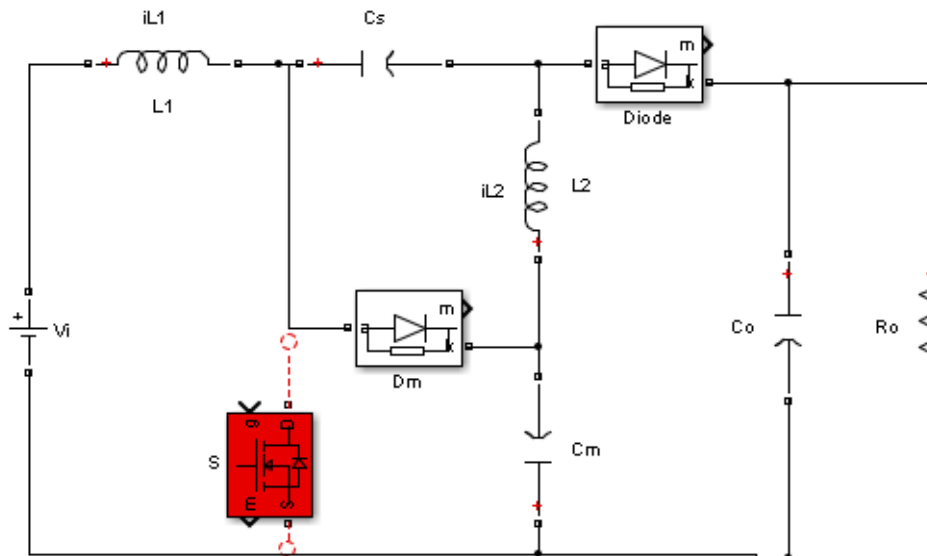
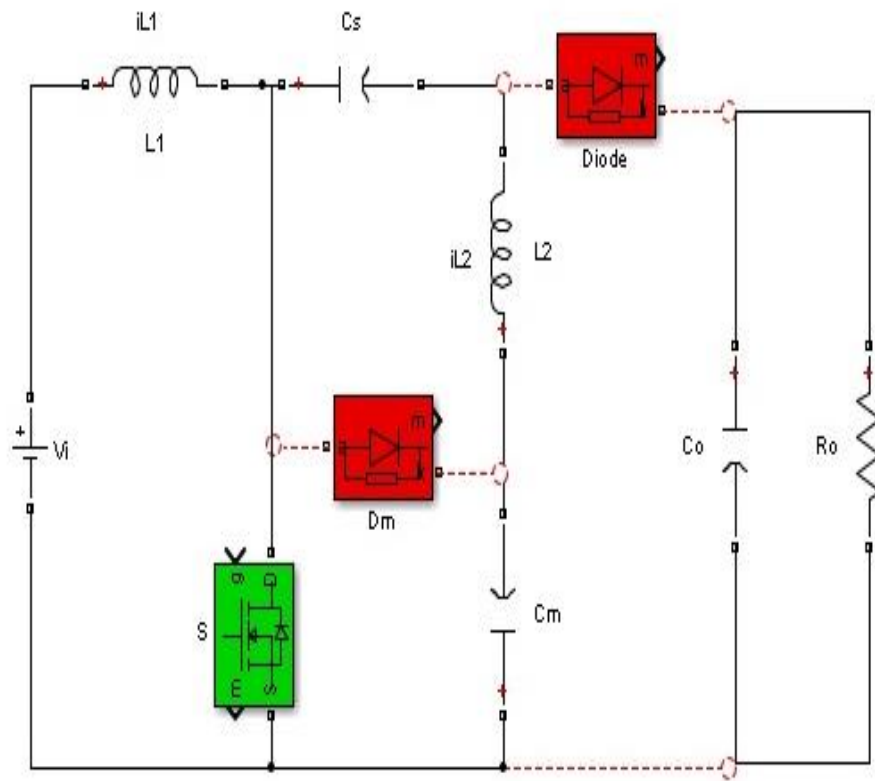

Fig.2.2 first operation stage

Second Operation Stage



[2] **Second stage** (t_1 , At the instant t_1 the switch S is turned on and the diodes D_m and D_o are blocked and the inductors L_1 and L_2 store energy. The input voltage is applied to the input inductor L_1 and the voltage V_{Cs} is applied to the inductor L_2 . The voltage V_{cm} is higher than the voltage V_{Cs} .

Fig.2.3 second operation stage

The main theoretical waveforms operating with hard switching commutation are presented in Fig. 2.4

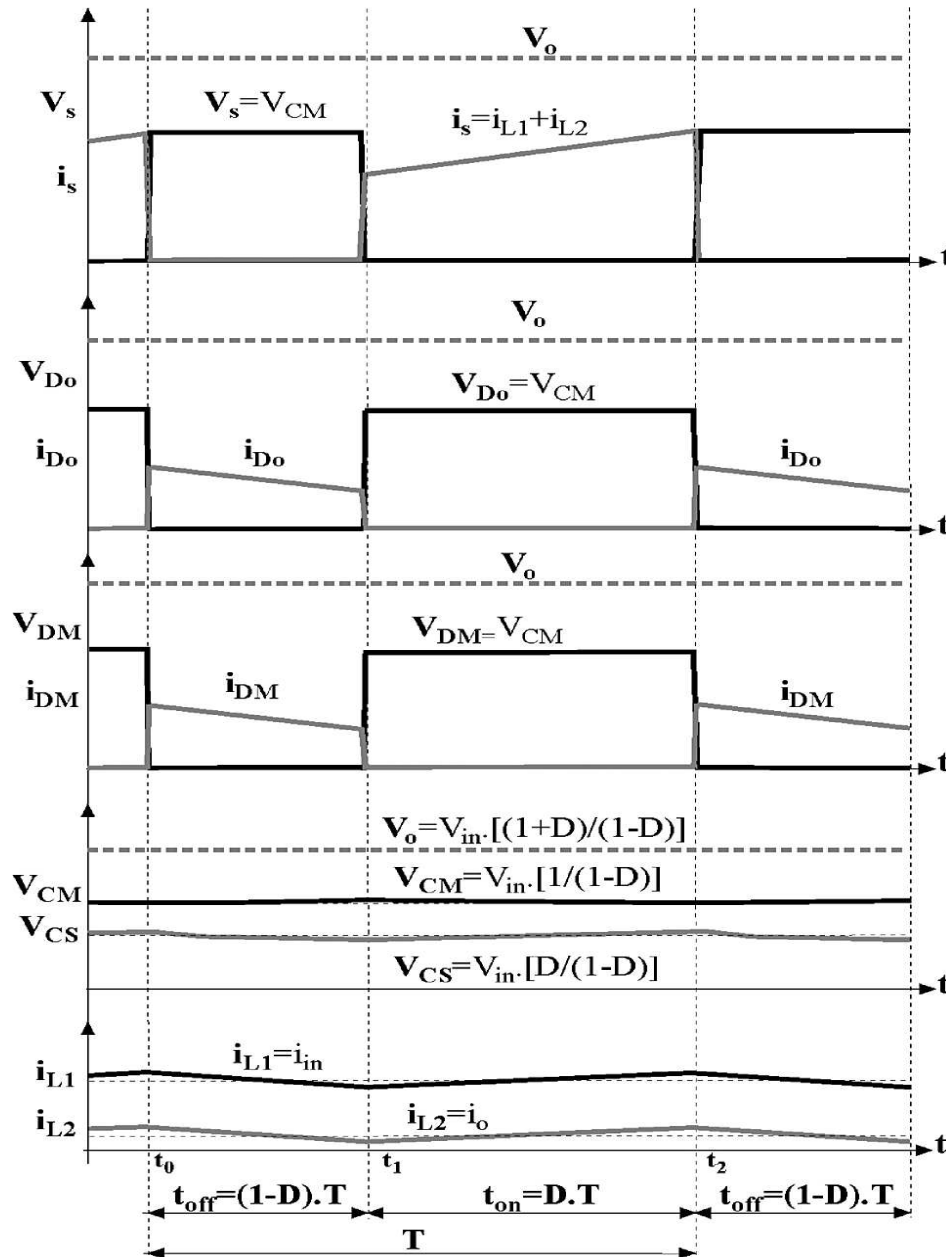

Fig.2.4 main theoretical waveforms operating with hard switching commutation

The voltage in all diodes and the power switch is equal to the capacitor CM voltage. The output voltage is equal to the sum of the Cs and Cm capacitors voltages. The average L1 inductor current is equal to the input current and the average L2 inductor current is equal to the output current.

PWM AND TRANSISTORS

PWM is the main part in designing a buck converter. By using pulse-width modulation (PWM) control controlling of output voltage is achieved by varying the duty cycle of the switch. Duty cycle intends to ratio of the period where power semiconductor is kept ON to the cycle period. Pulse width modulation (PWM) is a powerful technique for controlling analog circuits with a processor's digital outputs. PWM is operating in a wide variety of applications starts from measurement and communications to power control and conversion Control of PWM is usually effected by an IC is necessary for controlling the output. The transistor switch is the most important thing of the switched supply and controls the power delivered to the load. And also Power MOSFET's are more suitable than BJT at power output of

the order of 50 W. when selecting a transistor also must consider its fast switching times and able to withstand the voltage spikes produced by the inductor

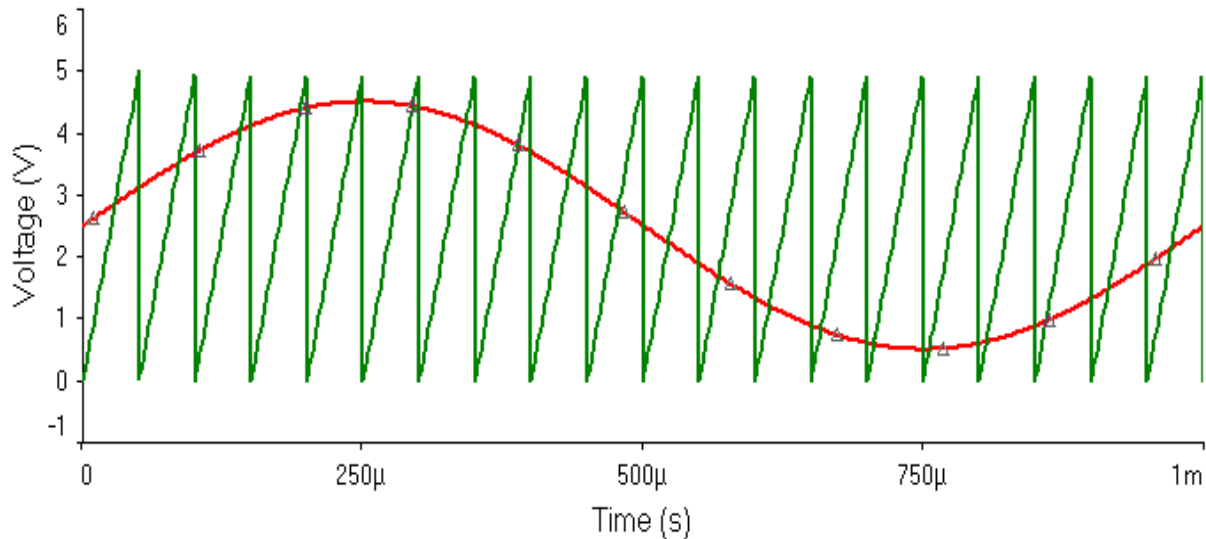

fig.2.5 Graph of Triangle wave and Sinusoidal control wave

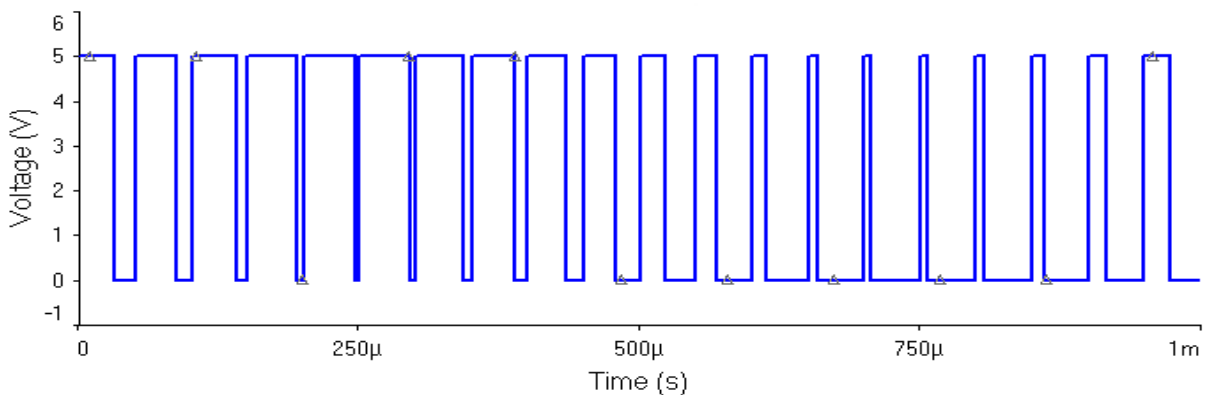

Fig 2.6 Graph of controlled square wave

This graph shows the resulting output of the comparator with the inputs shown. The pulse is high when the control signal is greater than the triangle wave. This results in a higher duty for high control signals.

PROPORTIONAL INTEGRAL CONTROLLER

A proportional integral controller (PI controller) is a generic control loop feedback mechanism widely used in industrial control systems. A PI regulator tries to correct the error between a measured process variable and a desired set point by calculating and then outputting a corrective action that can adjust the process accordingly.

The PI controller calculation (algorithm) involves three separate parameters The Proportional the Integral values. The Proportional value finds the reaction to the current error. The Integral obtains the reaction based on the sum of recent errors. The weighted sum of these three actions is used to adjust the process via a control element such as the position of a control valve or the power supply of a heating element. By tuning the three constants in the PI controller algorithm the PI can provide control action designed for specific process requirements. The response of the regulator can be described in terms of the responsiveness of the controller to an error the level to which the controller overshoots the set point and the degree of system oscillation. Point that the use of the PI algorithm for control does not guarantee optimal control of the system.

Proportional term

The proportional term makes a change to the output that is proportional to the current error value. The proportional response may be adjusted by multiplying the error by a constant K_p termed the proportional gain.

The proportional term is given by:

$$P_{out} = K_p e(t)$$

- I_o : Integral output
- K_i : Integral Gain
- e : Error = SP – PV
- τ : Time in the past involvement to the integral responses

A high proportional gain results in a large change in the output for a given change in the error. When proportional gain is too high the system can become unstable. In contrast a little gain results in a small output response to a large input error and a less responsive controller. When proportional gain is too low the regulate action may be too small when responding to system disturbances.

In the absence of disturbances pure proportional control will not settle at its target value but will maintain a steady state error that is a function of the proportional gain and the process gain. Despite the steady state offset both tuning principle and industrial practice indicate that it is the proportional term that should contribute the bulk of the output change.

Integral term

The contribution from the integral term is proportional to both the magnitude of the error and the duration of the error. Adding the instantaneous error over time gives the accumulated offset that should have been corrected previously. The emerged error is then multiplied by the integral gain and added to the controller output. The magnitude of the involvement of the integral term to the overall control action is determined by the integral gain K_i .

The integral term is given by:

$$I_o = K_i \int_0^t e \, dt$$

Where

- I_o : Integral output
- K_i : Integral Gain, a tuning parameter
- e : Error = SP – PV
- τ : Time in the past involvement to the integral responses

The integral term (when added to the proportional term) accelerates the movement of the process towards set point and eliminates the residual steady-state error that occurs with a proportional only controller. Meanwhile the integral term is responding to accumulated errors from the past it can introduce the present value to overshoot the set point value cross over the set point and then create a deviation in the other direction.

DESIGN AND SIMULATION OF CIRCUITS**Duty Cycle Calculation:**

The amount that the SEPIC converters step up or down the voltage depends primarily on the Duty Cycle and the parasitic elements in the circuit. The output of an ideal SEPIC converter is

$$V_o = \frac{D * V_i}{1 - D}$$

However this does not account for losses due to parasitic elements such as the diode drop V_d . These make the equation

$$V_o + V_d = \frac{D * V_i}{1 - D}$$

This becomes

$$D = \frac{V_o + V_d}{V_i + V_o + V_d}$$

The maximum Duty Cycle will occur when the input voltage is at the minimum. If $V_D = 0.5V$ the

$$D_{min} = \frac{1200V + 0.5V}{120V + 1200V + 0.5V} \approx .91$$

The minimum duty cycle will occur when the input voltage is at the maximum.

$$D_{min} = \frac{1200V + 0.5V}{220V + 1200V + 0.5V} \approx 8.4$$

Inductor Calculation

In theory the larger the inductors are the better the circuit will operate and reduce the ripple. However, larger inductors are more expensive and have a larger internal resistance. This greater internal resistance will make the converter less efficient. Creating the best converter requires choosing inductors that are just large enough to keep the voltage and current ripple at an acceptable amount.

$$L = \frac{V_i \min(D_{max})}{\Delta i_o \max F_{sw}} = \frac{120 \cdot 0.63}{(0.5A) \cdot 50KHz} = 3 \text{ mH}$$

inductors with low internal resistance and around 3mH will be ideal for both of the inductors in the circuit.

GENERAL

Simulation has become a very powerful tool on the industry application as well as in academic circles nowadays. This is now essential for an electrical engineer to understand the concept of simulation and learn its use in various applications. Matlab Simulator is one of the best ways to study the system or circuit behavior without damaging it. The tools for performing the simulation on computer in various fields are available in the market for engineering professionals. Lots of industries are spending a considerable amount of time and money in doing simulation before manufacturing their product. In majority of the research and development (R&D) work the simulation plays a very important role. Without simulation of proposed models it is quite impossible to proceed further. It must be noted that in power electronics, matlab simulation and a proof of concept hardware prototype in the laboratory are complementary to each other. While computer simulation must not be considered as substitute for hardware prototype. The goal of this chapter is to describe simulation of impedance source inverter with RRL and RLE loads using MATLAB tool.

SIMULATION RESULT

Simulations are carried for proposed SEPIC converter in both open and closed loops.

PROPOSED METHOD – SEPIC converter circuit

The Simulation circuit of the proposed SEPIC converter

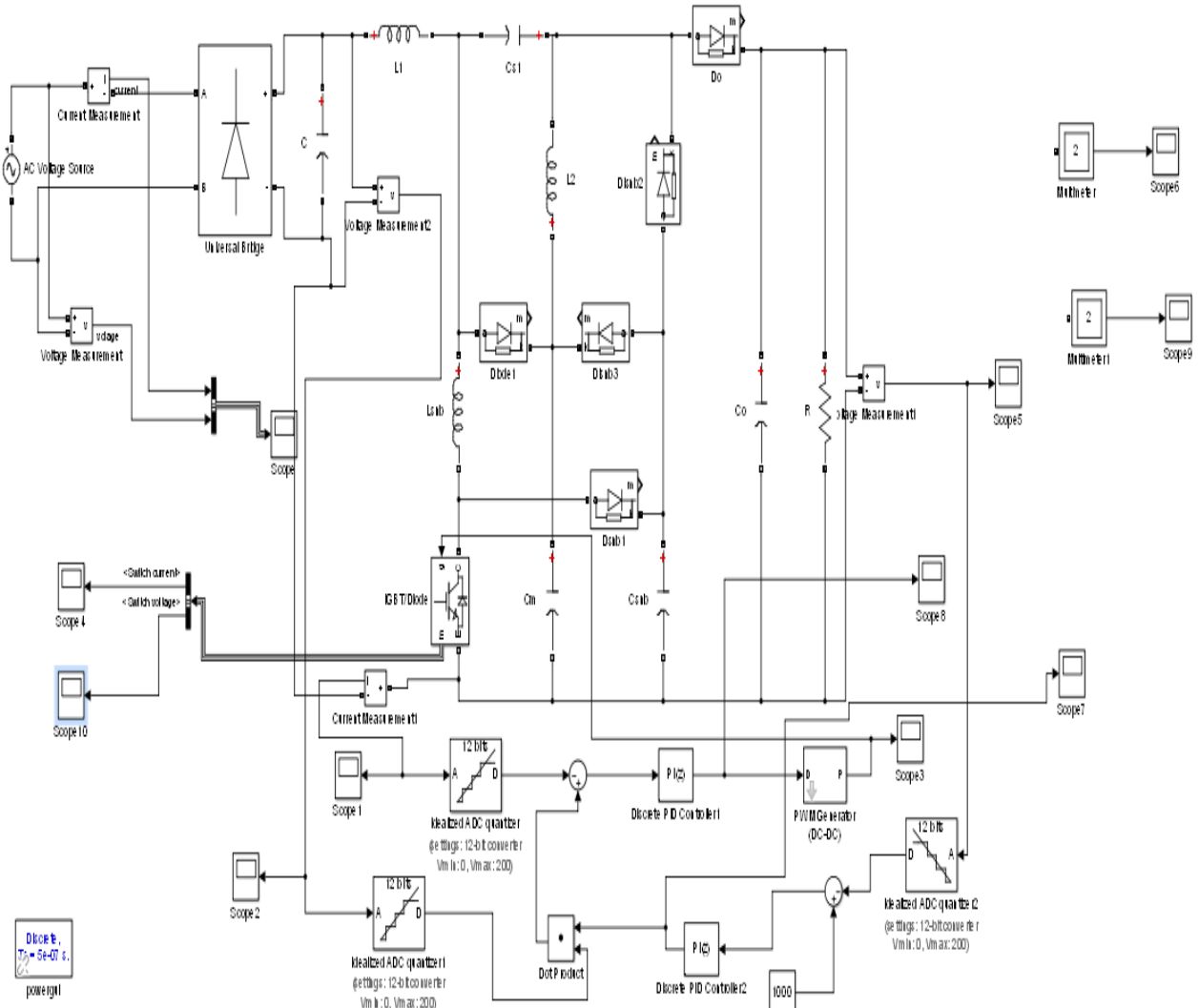

Fig 3.1 Simulation circuit of SEPIC converter

The output voltage is shown in the Fig.3.2

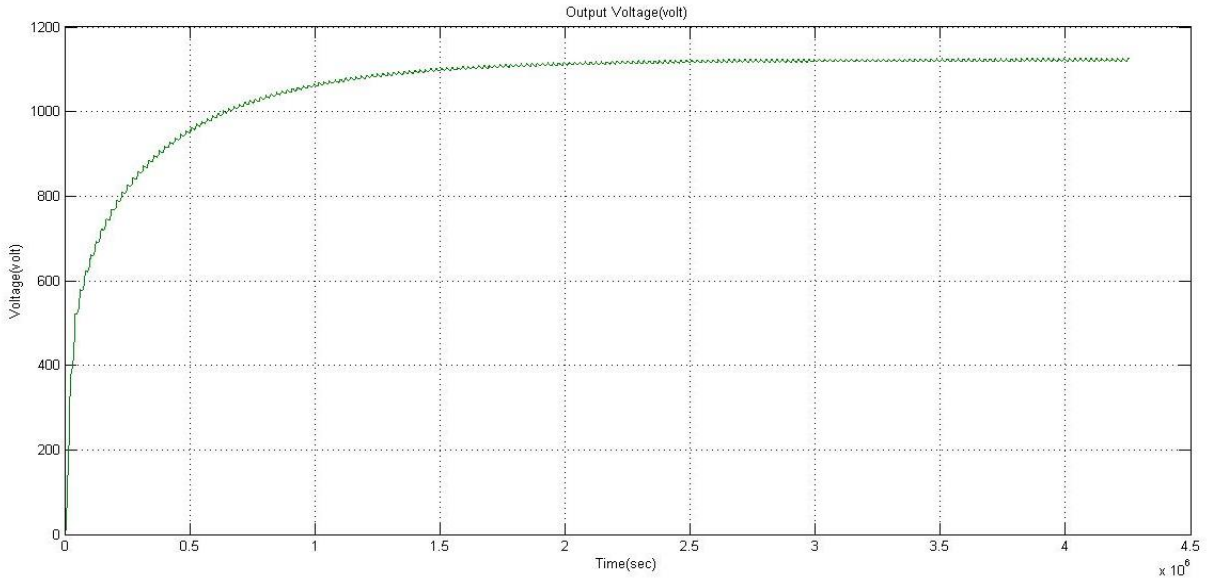

Fig.3.2 Output voltage

By performing simulation with the help of MATLAB 13. It is cleared that by giving an input voltage of 220 V and the output is 1200 V.

Inductor current L1 and L2 waveform is shown in the Fig.3.3

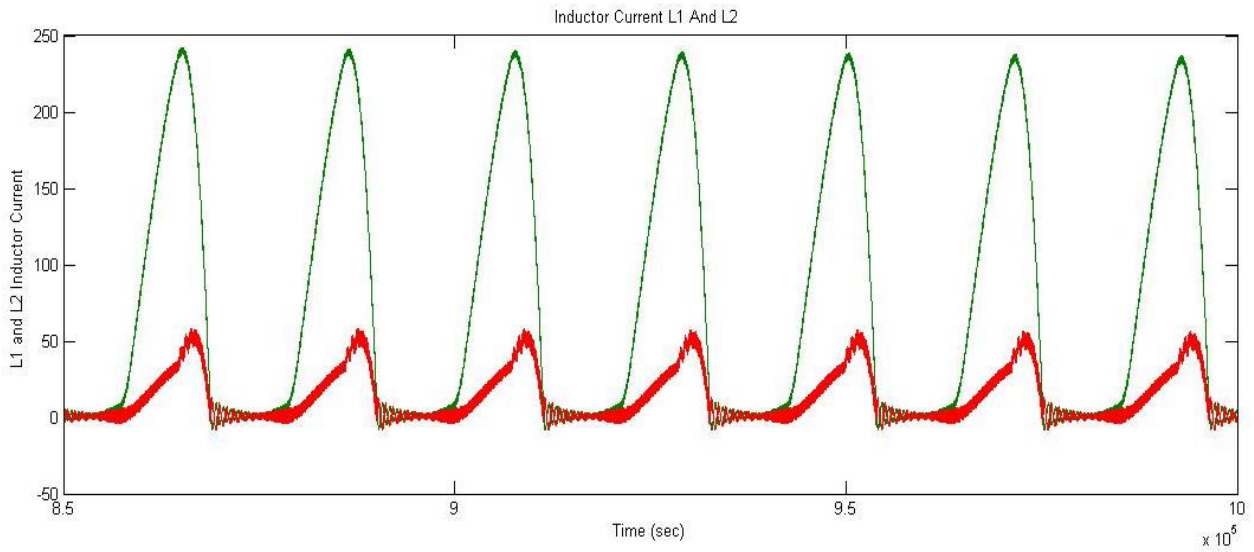

Fig.3.3 Inductor current L1 and L2 waveform

By performing simulation with the help of MATLAB 13. It is shown that L1 goes up to 245 Amp and L2 goes up to 60 Amp.

Capacitor Cm and Cs Voltages Waveform

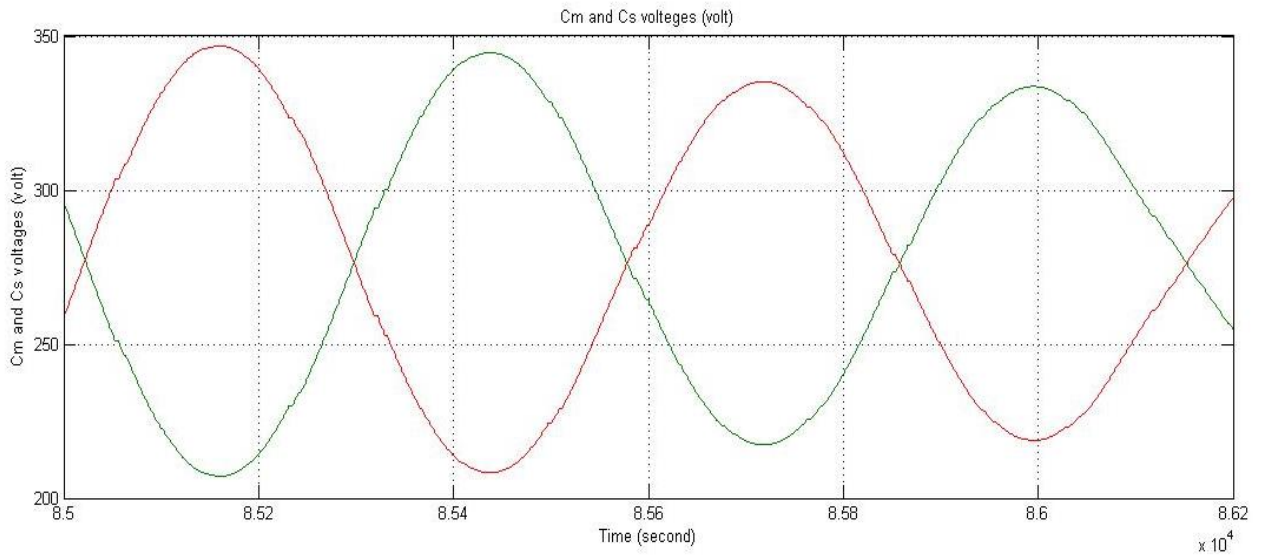

Fig3.4 Capacitor Cm and Cs Voltages Waveform

Switch Current And Voltage in fig 5.5.

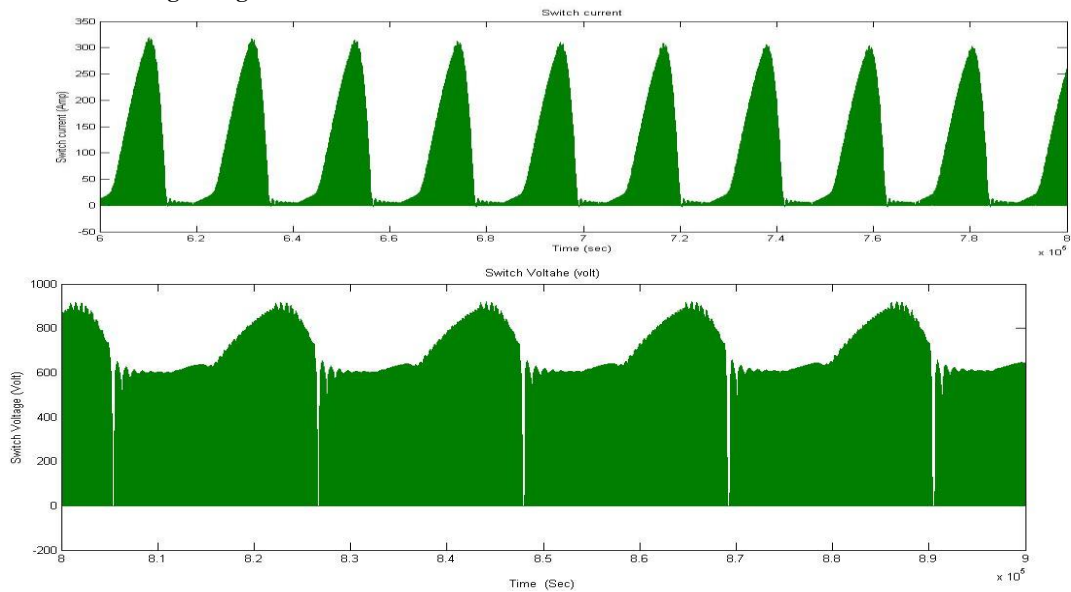

Fig 3.5 Switch Current And Voltage

Input voltage and Current Waveform

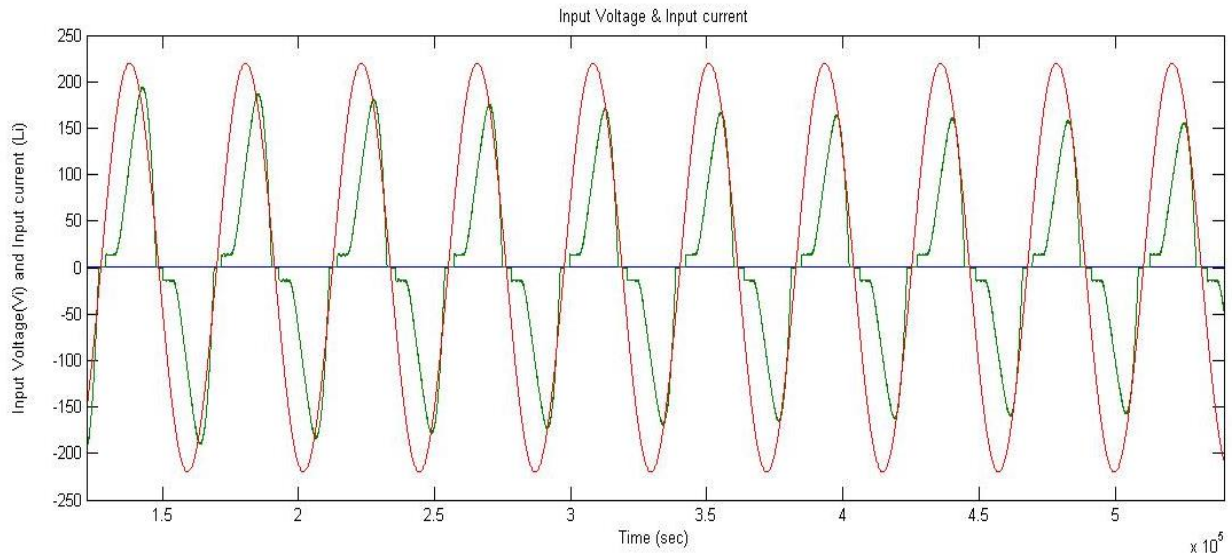

Fig 3.6 Input voltage and Current Waveform

5.4 Comparison of Theoretical Output waveform and Simulated Output Waveform

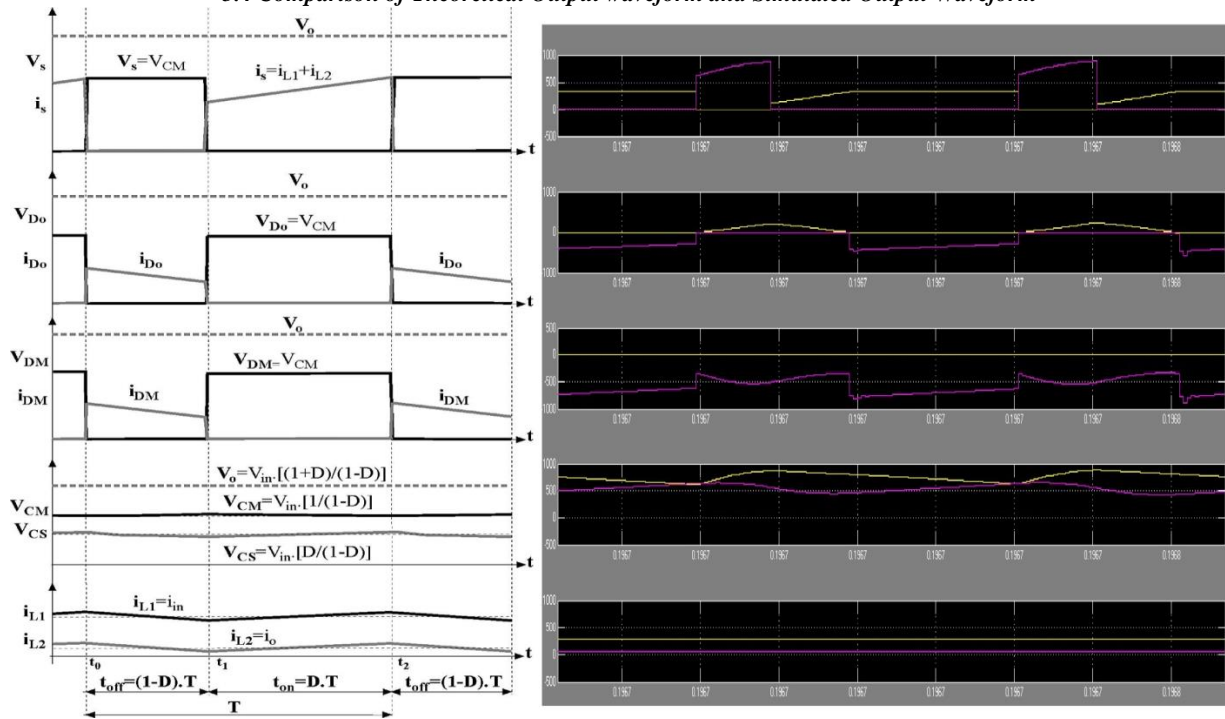

Fig. 3.7

CONCLUSION

A modified version of the SEPIC converter is proposed for the implementation of a high-PF rectifier suitable for universal line application. Although the proposed structure presents a higher circuit complexity than the classical boost converter the advantages obtained are the higher static gain for the operation with the lower input voltage range lower switch voltage operation higher efficiency operation with the lowest input voltage lower input current ripple and easy integration with a regenerative snubber. Three snubber circuits

are proposed in order to obtain a reduction of the diode reverse recovery current problem, and also obtaining turn-on and turn-off soft switching for all input voltage ranges and output power variation. The average current mode control is used for the classical boost converter and also for the proposed converter, and the dynamic response obtained with both converters is approximately the same. The experimental results are obtained with the implementation of a rectifier with an output Voltage equal to $V_o = 1200$ Volt for an input voltage of 220V.

REFERENCES

- [1] H. Cheng, K. Smedley, and A. Abramovitz, "Wide input wide output (WIWO)dc-dc converter," IEEE Transactions on Power Electronics, vol. 25, no. 2, Feb 2010.
- [2] D. Maksimovic and S. Cuk, "Switching converter with wide dc conversion range," IEEE Trans. Power Electron., vol. 6, no. 1, pp. 151–157, Jan. 1991.
- [3] K. Yao, M. Ye, M. Xu, and F. C. Lee, "Tapped-inductor buck converter for high-step-down dc-dc conversion," IEEE Trans. Power Electron., vol. 20, no. 4, pp. 775–780, Jul. 2005.
- [4] J.-H. Park and B.-H. Cho, "Nonisolation soft-switching buck converter with tapped-inductor for wide-input extreme step-down applications," IEEE Trans. Circuits Syst. I, Reg. Papers, vol. 54, no. 8, pp. 1809–1818, Aug. 2007.
- [5] K. Yao, Y. Ren, J. Wei, M. Xu, and F. Lee, "A family of buck type dc-dc converters with autotransformers," in Proc. Appl. Power Electron. Conf. Expo. (APEC 2003), pp. 114–120.
- [6] K. Nishijima, K. Abe, D. Ishida, T. Nakano, T. Nabeshima, T. Sato, and K. Harada, "A novel tapped-inductor buck converter for divided power distribution system," in Proc. IEEE PESC Conf. (PESC 2006), Jun., 18–22, pp. 1–6.
- [7] G. Spiazzi and S. Buso, "Power factor preregulator based on modified tapped-inductor buck converter," in Proc. IEEE PESC Conf., 1998, vol. 2, pp. 873–879.
- [8] F. L. Luo and H. Ye, "Positive output cascade boost converters," Proc. Inst. Electr. Eng. Electr. Power Appl., vol. 151, no. 5, pp. 590–606, Sep. 2004.
- [9] Q. Zhao and F. C. Lee, "High efficiency, high step-up dc-dc converters," IEEE Trans. Power Electron., vol. 18, no. 1, pp. 65–73, Jan. 2003.
- [10] N. Vazquez, L. Estrada, C. Hernandez, and E. Rodriguez, "The tapped-inductor boost converter," in Proc. IEEE Int. Symp. Ind. Electron., Jun., 4–7, 2007, pp. 538–543.